



Driving Human Audio Experience

CORPORATE PRESENTATION

Mid & Small in Milan 2022

29 November 2022



A WORLDWIDE LEADER IN PROFESSIONAL AMPLIFIERS

QUEEN ELISABETH HALL
ANTWERP



POWERSOFT AT A GLANCE

Powersoft is a global leader in **audio amplification technologies**, **advanced signal processing**, and **unique transducer systems** for the pro-audio sector

Powersoft specializes in the **design, production, and marketing of landmark products** for sophisticated customers and operators of the professional audio market. These products are the result of its strong emphasis on **R&D and continuous innovation**



Net Profit
€ 1.4 M

27 Years
of Success

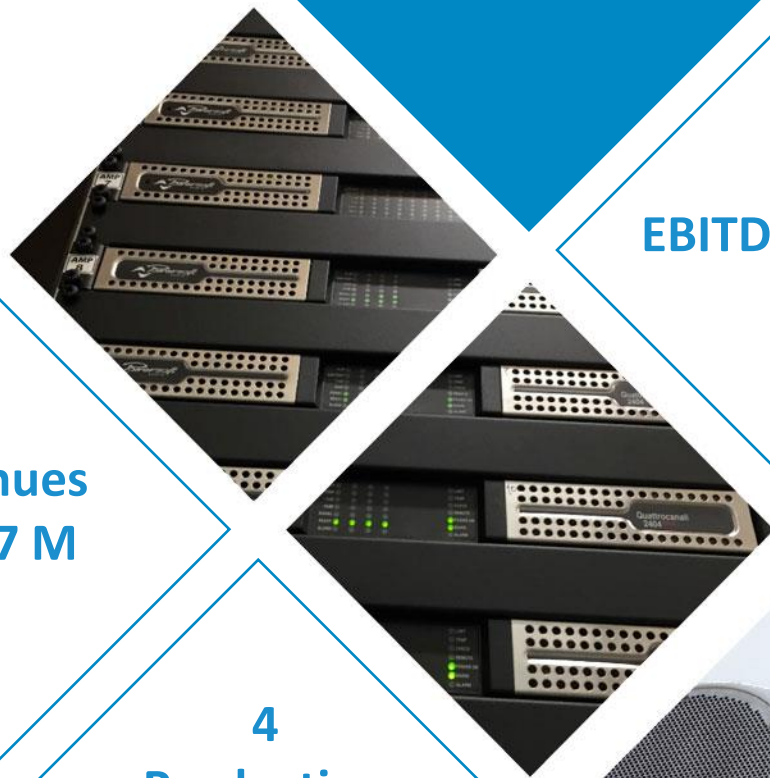

Revenues
€ 19.7 M

4
Production
Plants*



~30
International
Patents



116
Headcounts

EBITDA Margin
19%

1H2022
FINANCIAL FIGURES

* 3 production plants are in outsourcing

AN ITALIAN EXCELLENCE POSITIONED AT THE HIGH-END PROFESSIONAL AUDIO MARKET

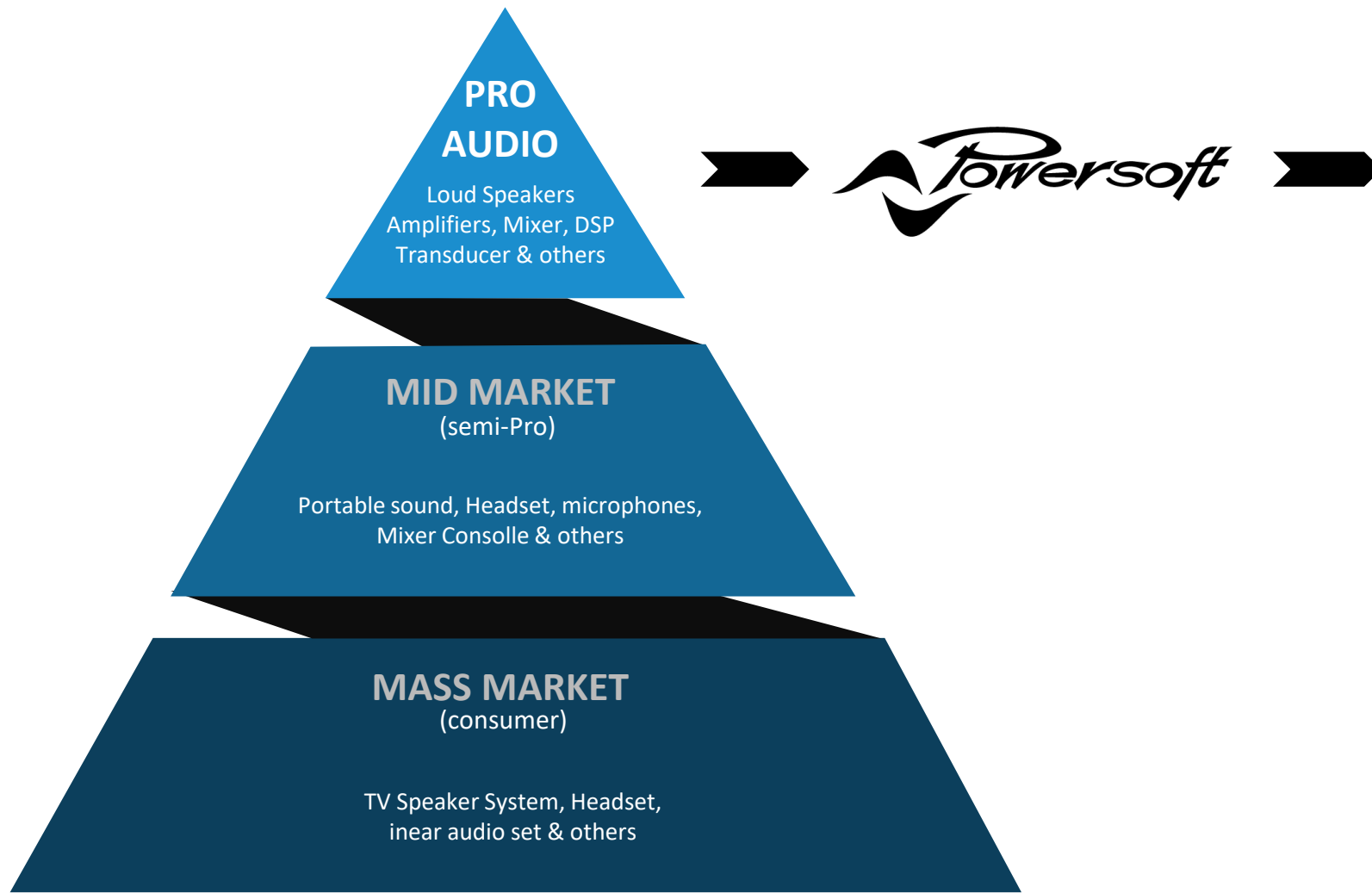

AT THE TOP OF THE PIRAMID

- A pioneer in the **high-end professional audio market**
- Globally recognized **market setter of unrivalled cutting-hedge products** in a thriving market
- Serving a broad range of clients, both **professional customers and audio-device makers**
- **Over 27 years as a forefront player in the market**, set to face future challenges and to exploit new opportunities



AT THE HEART OF THE PRO AUDIO SYSTEM

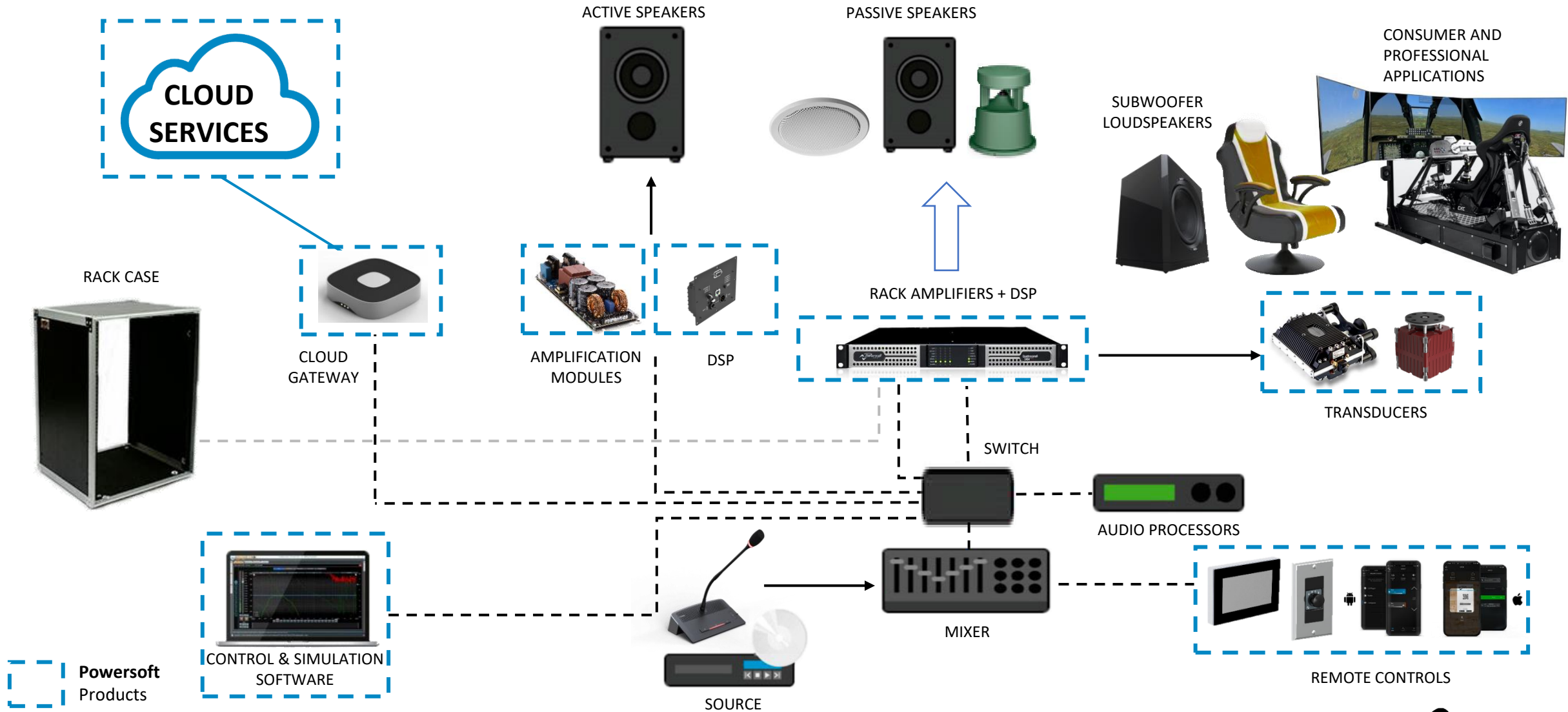

POWERSOFT AS PIONEER IN THE MARKET

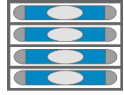

1995

Class D POWER
AMPS



IMMERSIVE SOUND

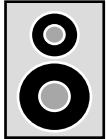

2005

AMPLIFICATION
MODULES



2021

SYSTEM
SOLUTIONS

- Dynamic Music Distribution systems
- Multi channels amps for immersive systems

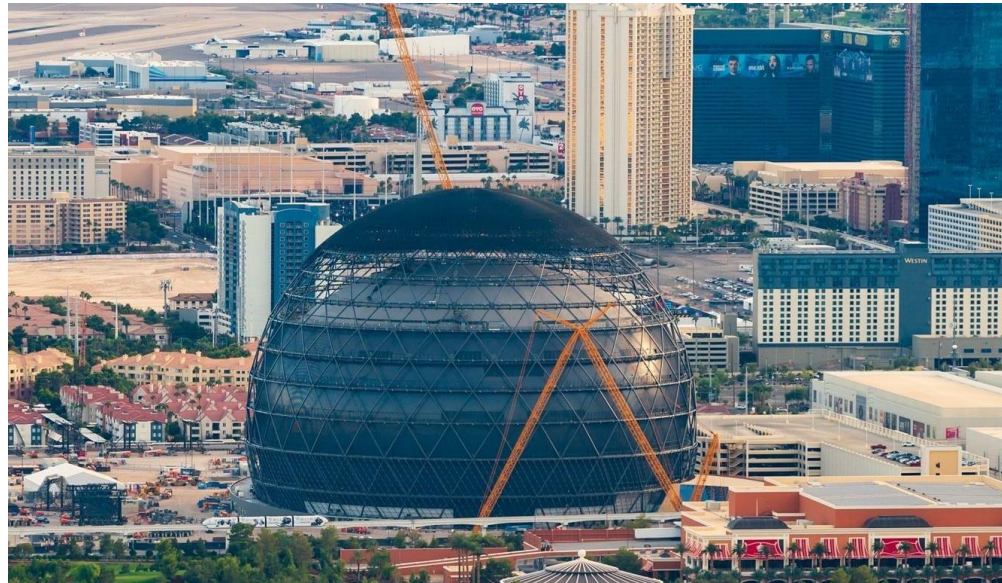

PATENTED TECHNOLOGIES

- Innovative topologies for efficiency improvement in **switchmode power converters**
- **Control methods** for optimizing and compensating acoustical systems non linearities and enhancing global performances
- **Electromechanical conversion systems** for highly efficient and powerful acoustic transduction
- **Acoustical solutions** to increase compactness of acoustical cabinets and sound pressure level capabilities
- **Modular and flexible multichannel amplification platform** for large scale/channels count applications
- Efficient **Long Range Wireless Power Distribution** for domestic and commercial appliances
- **Self sufficient acoustical ambient enhancement**, for domestic and commercial applications



WHAT'S NEXT?



PRODUCTS AND SOLUTIONS VS MARKETS

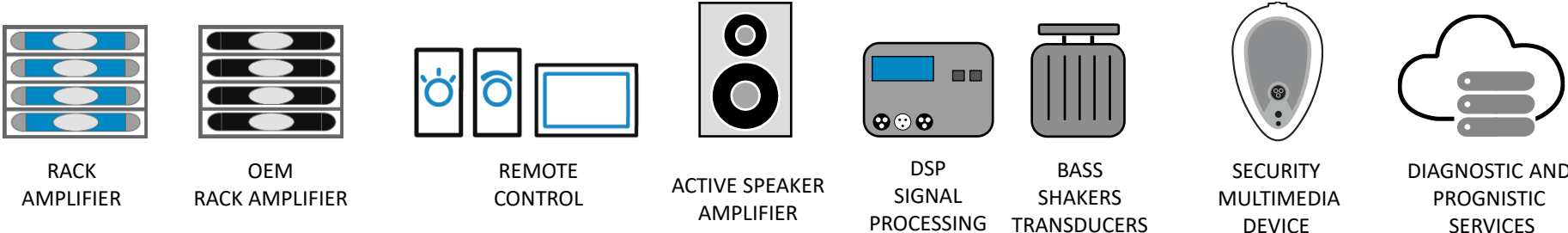

STRONG INTERNATIONAL PRESENCE

1H2022 REVENUES
BREAKDOWN

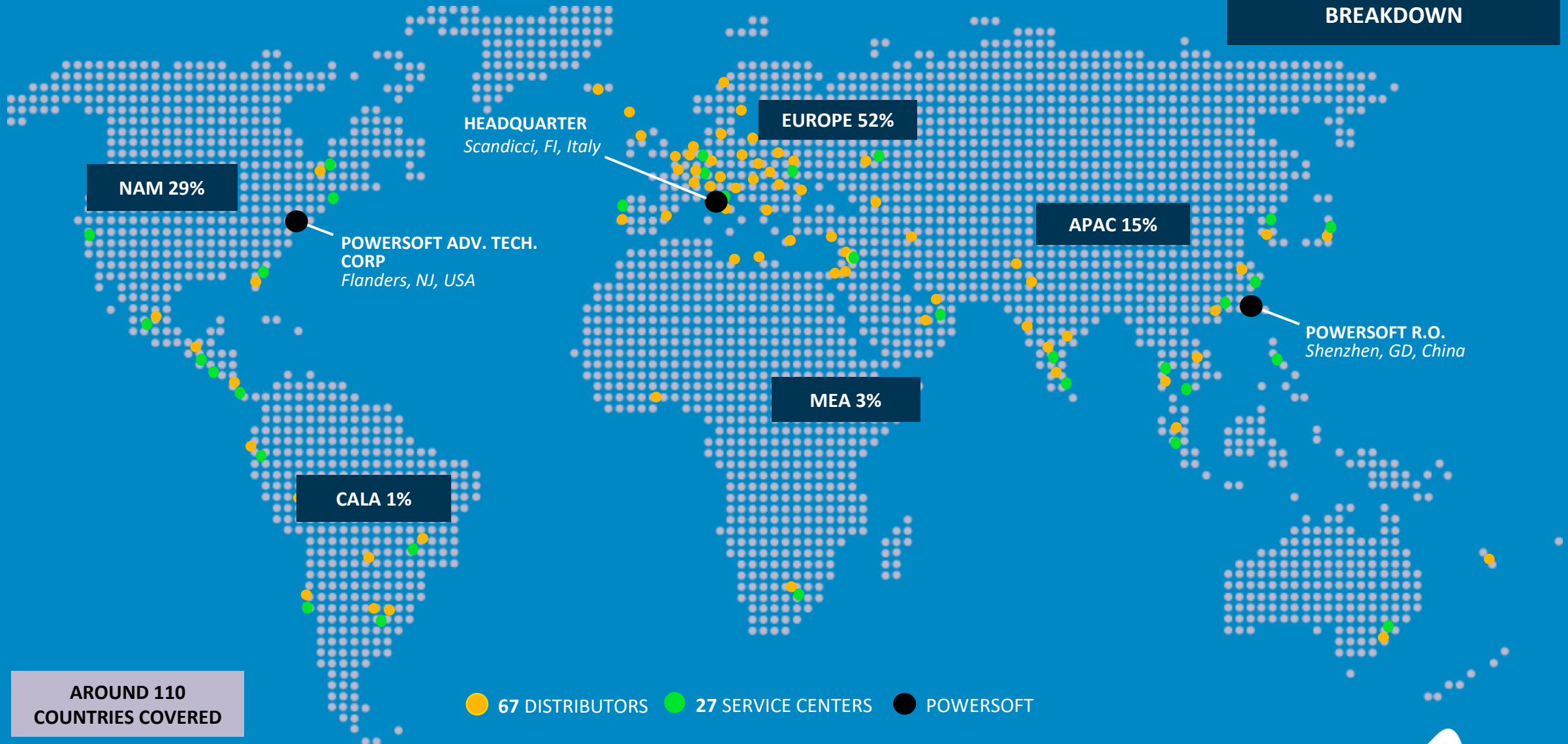

DIVERSIFIED AND EFFICIENT BUSINESS MODEL

Core Strengths:

- Internal «Lean» Production
- Large production capacity potential
- Purch. Dept. with high-level technical capabilities
- R&D Dept. Focus on Innovation and products re-design activity to address current shortage of components

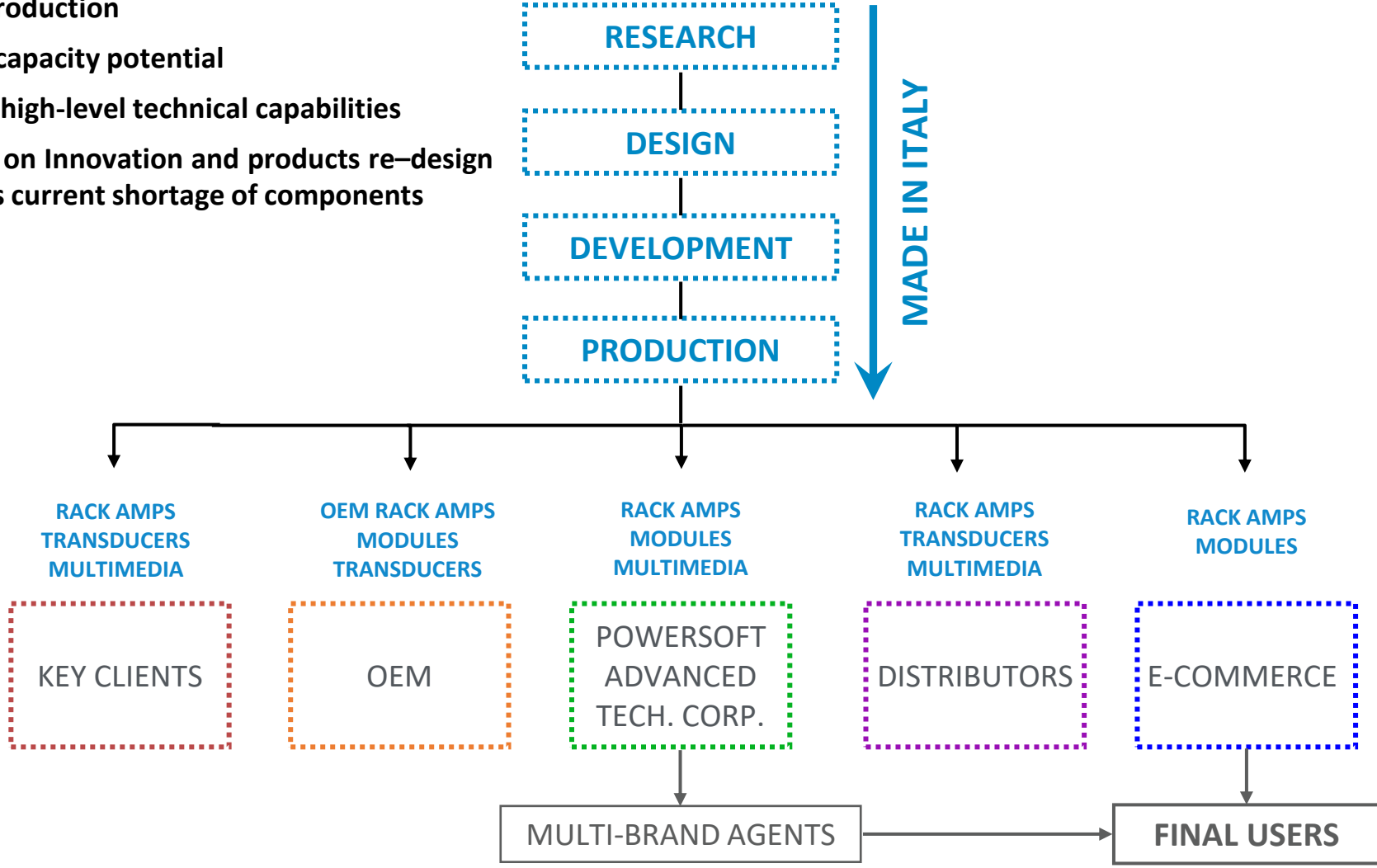



MARKET TREND & STRATEGY

SUPERBOWL 50 HALF
SANTA CLARA



Photo credit: Ezra Shaw, Getty Images

THE RIGHT CHOICE: INCREASING FOCUS ON GROWING SEGMENTS

Reference market for target applications growing high single digit CAGR in next 7Y expecting to reach 1 billion euros by 2029

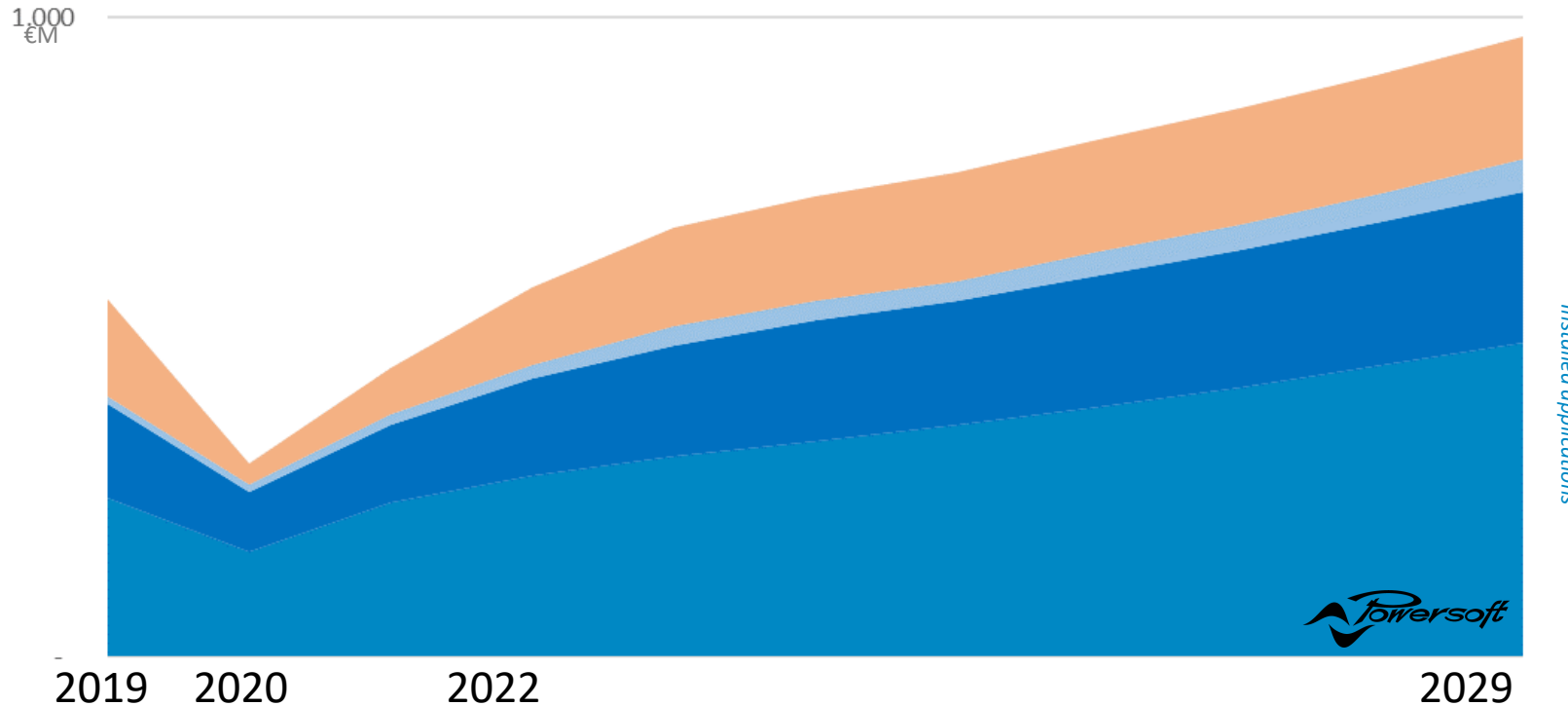

Touring and Rental: recovery after pandemic is slower than expected

Immersive applications: growing quickly, niche market

Leisure applications: resilient and growing due to long term projects

Commercial applications: strong growth expected in the next few years

- Powersoft outperforming vs market average in 2020 and 2021
- Company stronger focus on installed business allows optimistic forecast considering relevant market size and growth
- Important business opportunities on immersive applications echo awareness in leisure installed vertical markets



A VERY FRAGMENTED MARKET WITH ROOM FOR CONSOLIDATION

Main market players for company size and level of vertical integration of products and / or offered services

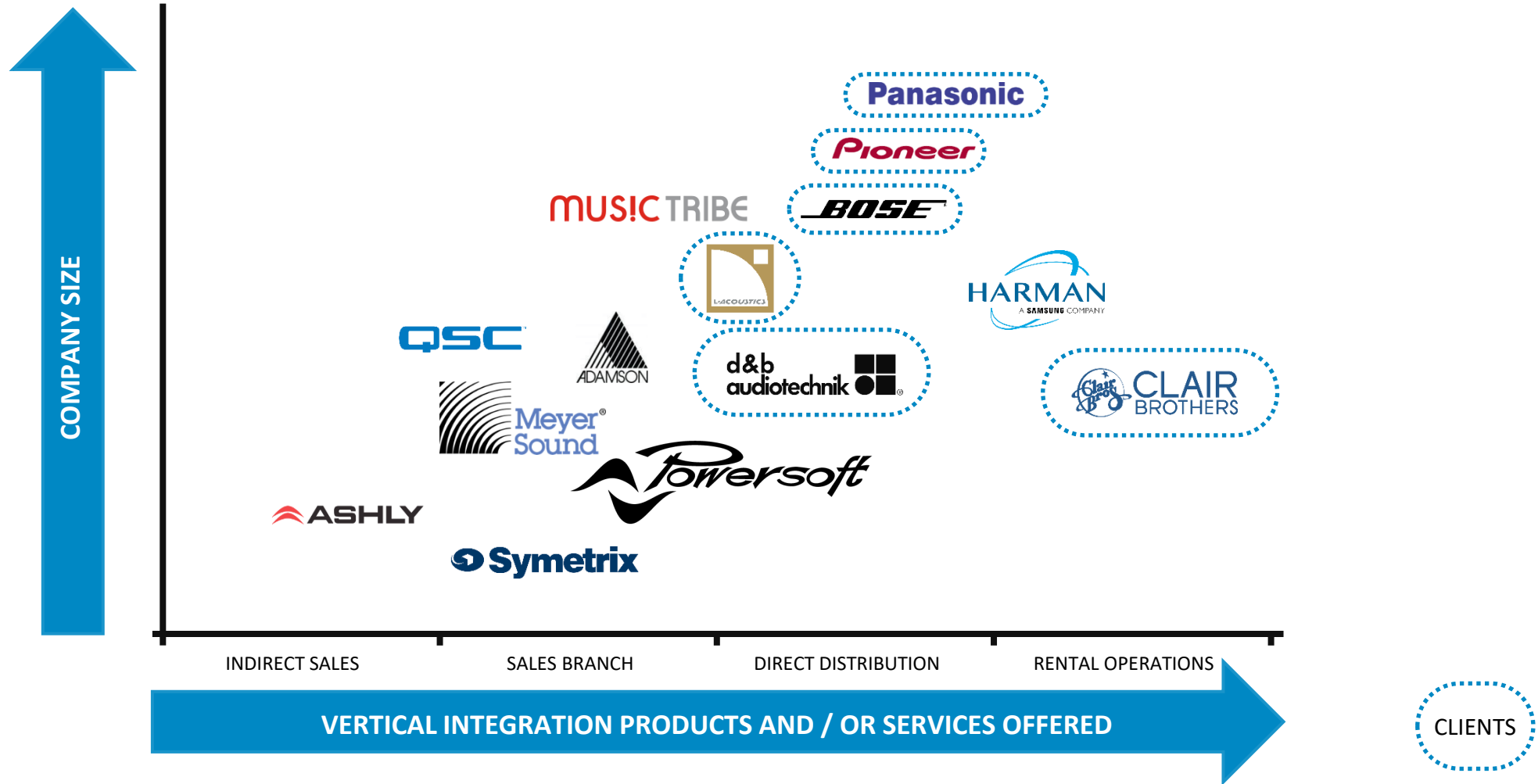

Data source: Powersoft elaboration based on primary research panels



GROWTH DRIVERS: THREE PILLARS STRATEGY

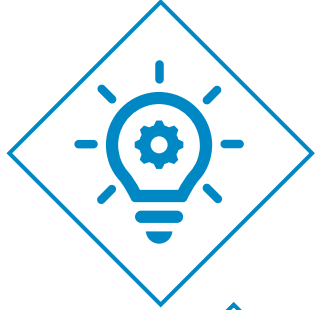

FROM PRODUCT COMPANY TO SOLUTION PROVIDER



MOVING TOWARDS A TRUE MULTINATIONAL GROUP



FOCUS ON INNOVATION AND NEW TECHNOLOGIES



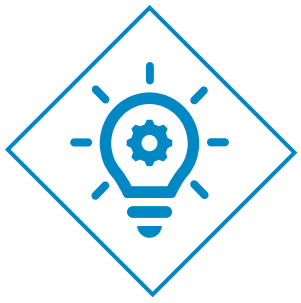

GROWTH DRIVERS: FROM PRODUCT COMPANY TO SOLUTION PROVIDER

STRATEGY

Focus on **proprietary solutions** designed for **specific target proAudio applications** suitable for **installed vertical markets**:

- **Hospitality**
- **Retail**
- **Higher Education**
- **Houses of Worship**
- **Venues**

Launch of value added and software-based services with cloud-based features to exploit **upselling/cross-selling potential**

ACTION

- **Akira Mochimaru** as new Global Marketing Director, previous General Manager for Bose Professional
- **Leverage company's WW presence** by partnerships with WW Key Accounts
- **New distribution channels:** E-commerce for B2B
- **New Salesforce CRM platform** to improve process automation
- **New products roadmap** to fulfil Powersoft offer
- **IoT & Cloud based services**

Dynamic Music Distribution

High-quality music distribution in multi-zone/source applications



Smart Cities

Connecting city and people through DEVA, a device that integrates multiple data gathering accessories





GROWTH DRIVERS: MOVING TOWARDS A TRUE MULTINATIONAL GROUP



USA

Boost presence in **US, Canada and Latin America** market:

- **Strengthened US headquarter** thanks to additional new management, operational and sales staff
- **Focus on key clients** with dedicated sales force (consultant liason)



CHINA

Presence strengthened in **China**:

- **Opened a local office** with new professionals to strengthen the **direct commercial presence**, alongside the local distributor and the key clients



EMEA

Consolidate Leadership in **EMEA**:

- **Widen presence** through additional distributors in strong potential markets as **Italy, France, Greece, Denmark, Norway and Sweden**
- **Partnership with strategic players** to enter new markets





GROWTH DRIVERS: FOCUS ON INNOVATION AND NEW TECHNOLOGIES



Ideofarm

Powersoft's own **growth accelerator** to support **new projects** and **innovative technologies**



Powersoft's **Trademark** which identifies **environmental friendly products**



Powersoft is the winner of the **Corporate & Social Responsibility Awards 2021**

INNOVATIONS

High entry barriers

- Top level R&D laboratory
- More than 30 international patents
- Many trademarks registered in over 30 countries
- **Innovative SME** (certified in the Italian Innovators public register)

High Energy Efficiency

- Environmentally friendly products
- Small sizes, huge power

ADDED VALUE SERVICES

My Powersoft In Cloud Platform

~30
INTERNATIONAL PATENTS

~8-10%
OF REVENUES INVESTED IN R&D

~33
R&D PERSONNEL
(~ 30% OF EMPLOYEES)



INAI TECH



STRONG EQUITY STORY BACKED BY SOLID FINANCIALS

ASCENDAS HEADQUARTERS
SINGAPORE



2022 HY RESULTS: KEY FINANCIAL INDICATORS UP AND PROFITABILITY ABOVE PRE-PANDEMIC LEVELS

- Group's strategy of repositioning **from Product Company to Solution Provider is bearing fruits**
- Consolidated **revenues at € 19.7 M** ($\approx +25\%$)
- **EBITDA at € 3.7 M** ($\approx +77\%$), sound EBITDA margin above 19% from 13.4% of last year
- **Net Profit at € 1.4 M** + 54%
- **Positive NFP** of € 21.3 M thanks to **strong operating cash flow generation**
- **Double-digit order book growth** – both in the amplifier market and in the vertical target segments within the Install sector



FINANCIAL HIGHLIGHTS

REVENUES €/M

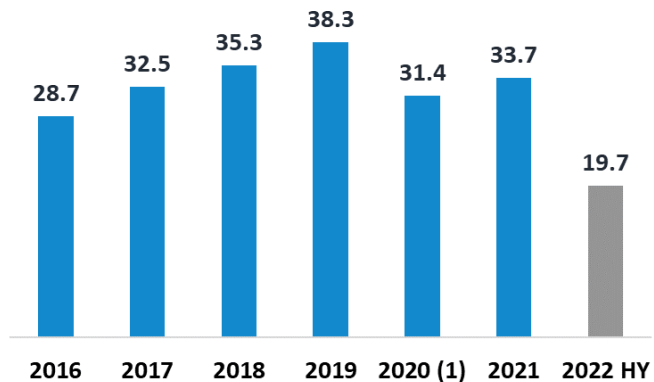

EBITDA €/M – EBITDA MARGIN %

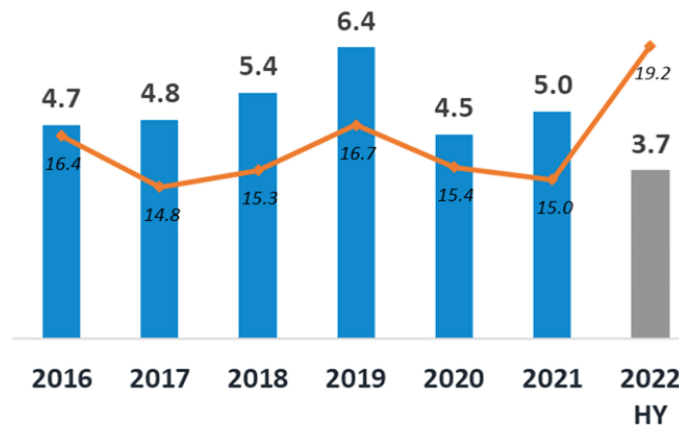

EBIT €/M – EBIT MARGIN %

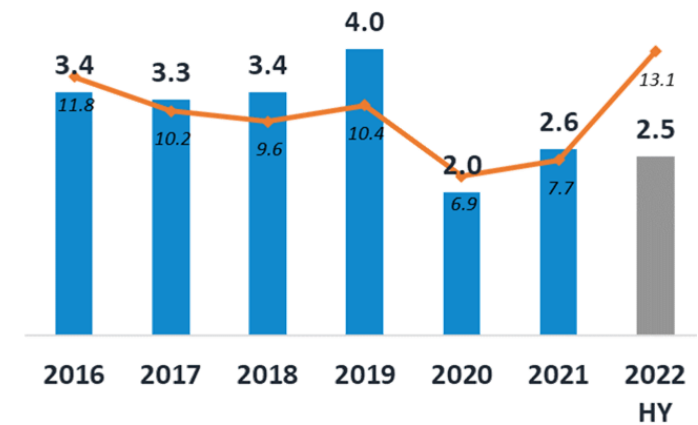

NET PROFIT €/M

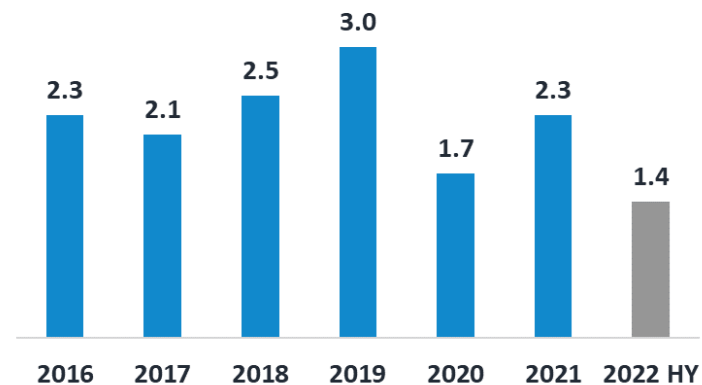

NFP (CASH) €/M

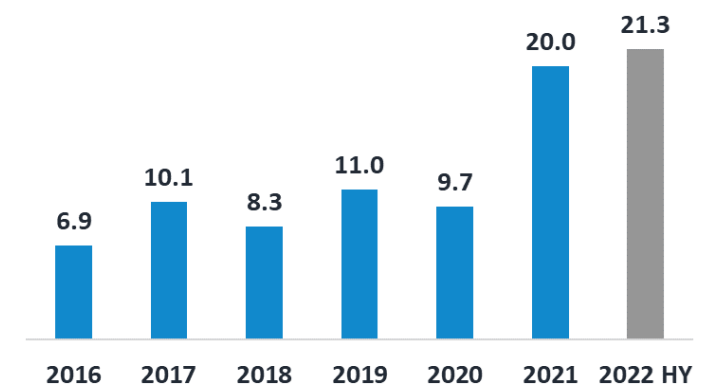

A solid equity story and sound financials, which allows the company to face, with flexibility and speed, the changing commercial and industrial needs, and growth goals



STRONG GROWTH RECORDED IN HY 2022

TOTAL REVENUES €/M

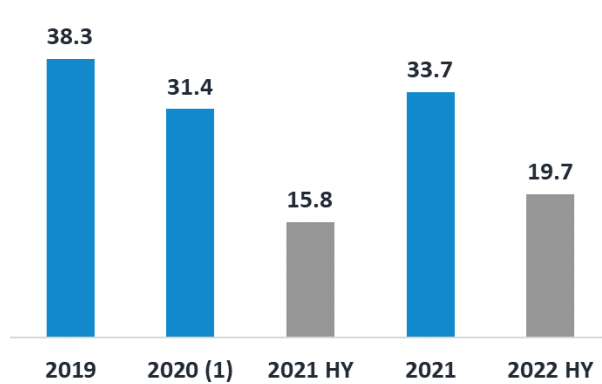

EBITDA €/M

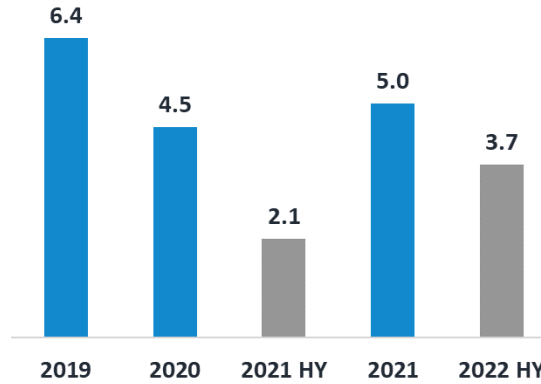

NET PROFIT €/M

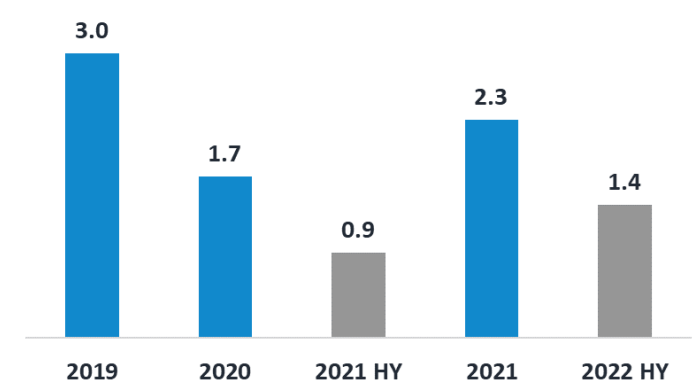

- **Sales Revenues at € 19.7 M, +24.7% YoY**

- Europe (+26.4%) & APAC (-7.1%) YoY
- North America (NAM) +40%
- **Wide visibility of the backlog**

- **EBITDA at € 3.7 M, + 76.7% YoY & EBITDA margin at 19%**

- **The cost of goods** up YoY due mainly to the increase in volumes sold, but with a lower incidence on sales due to:
 - products mix effect;
 - Increase of price list.
- **Expenses related to the commercial dept.** increased as a sign of recovery in the business of reference and investments in marketing aimed at increasing sales volumes

- **Increase in operating margin** and less than proportional increase in D&A and provisions recorded during the year

- **Net Profit at € 1.4 M, +53.7%** vs € 0.9 M in 1H 2021 with an incidence on turnover of 7.3%



CONSOLIDATED EBITDA – EVOLUTION 1H 2021 - 1H 2022

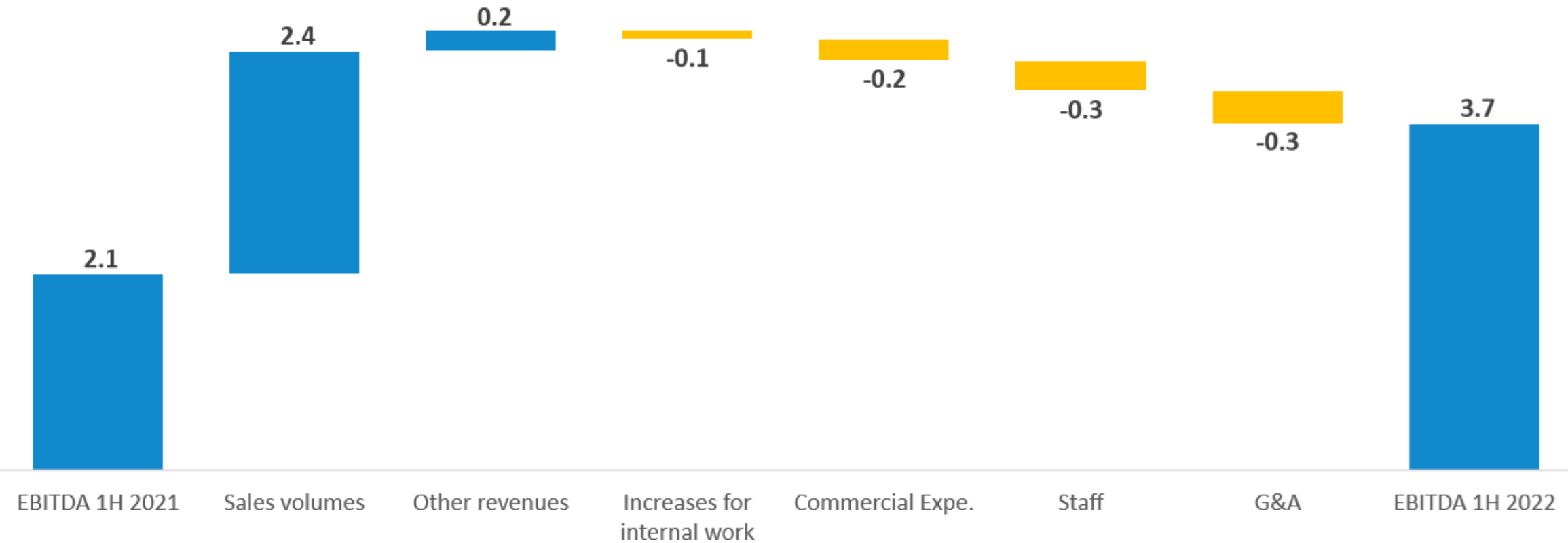

SOUND BALANCE SHEET

NET WORKING CAPITAL €/M

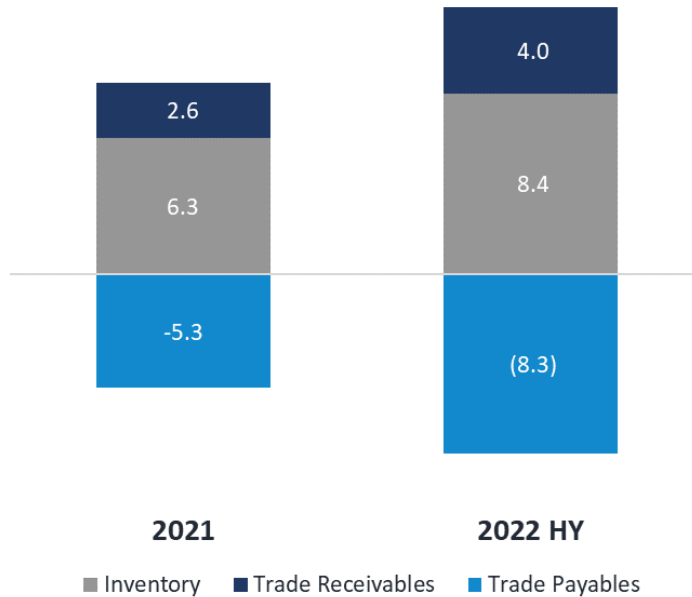

NET FINANCIAL POSITION €/K

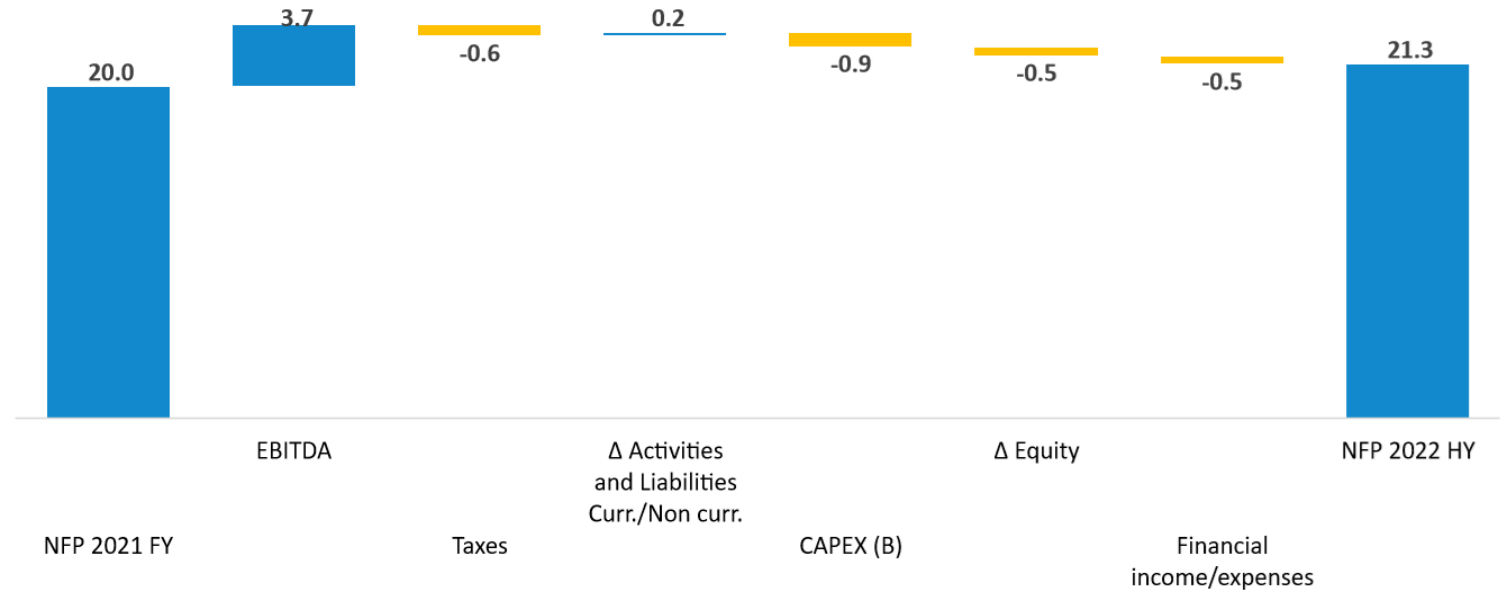

NWC down to € 3.1 M in 1H 2022 due to increases in:

- payables to suppliers
- trade receivables
- inventories

NFP at € 21.3 M, compared to € 19.9 M at 31st Dec. 2021, and mainly composed of:

- cash and cash equivalents for € 17 M,
- securities in portfolio for € 5.3 M, and
- negative items for € 0.9 M



KEY TAKEAWAYS

- **Faster growth** and **strong competitive positioning** thanks to **R&D investments** in **product innovation** and **offering expansion**
- **Improving market share in US and in China** by strengthening traditional sales channels and the development of new ones
- **Partnerships with industry players** and **opportunities** for long-term organic growth
- **Large install projects** and **audio immersive venues**: potential add on
- The results for the 1H show a marked improvement in all the main economic-financial aggregates and a **return of growth and profitability above pre-pandemic levels**
- These results confirm the validity of the Group's strategic choices and of its **repositioning from Product Company to Solution Provider**
- **The good trend in demand continues to be reflected in the order backlog**



APPENDIX



GOVERNANCE

BOARD OF DIRECTORS

-  **Carlo Lastrucci**
Chairman
-  **Luca Lastrucci**
CEO
-  **Claudio Lastrucci**
Director
-  **Antonio Peruch**
Director
-  **Luca Giorgi**
Director
-  **Paolo Blasi**
Independent Director
-  **Lorenzo Lepri**
Non-executive Director

STOCK FIGURES

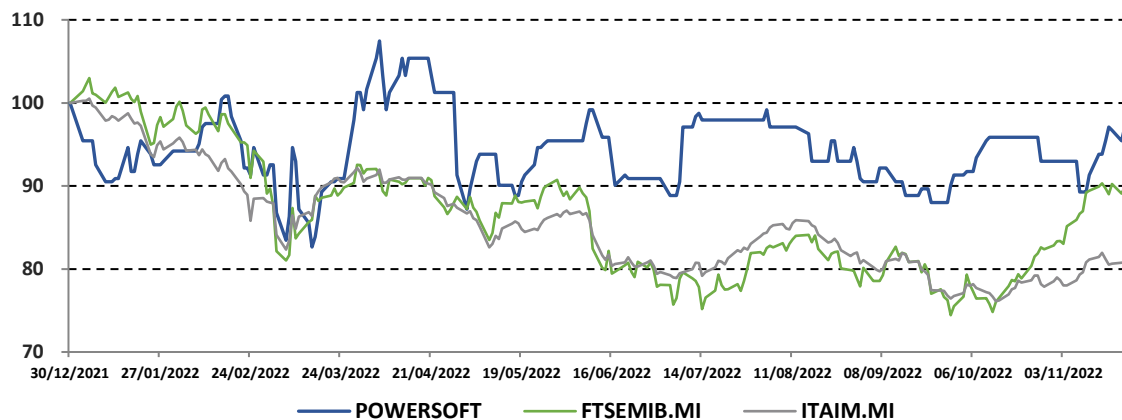

IPO: 17/12/2018

Shares: 11,709,992

Market: Euronext Growth Milan

Price (22/11/2022): € 4.70

Market Cap (22/11/2022): ≈€ 56 M

Average Daily Volume: ≈ 4.2 K

BOARD OF STATUTORY AUDITORS

-  **Luigi Fazzini**
Chairman
-  **Carlo Consigli**
Standing Statutory Auditor
-  **Federica Menichetti**
Standing Statutory Auditor
-  **Massimiliano Manfredi**
Alternate Statutory Auditor
-  **Paolo Limberti**
Alternate Statutory Auditor

AUDIT FIRM



SHAREHOLDINGS AND GROUP ORGANIZATION CHART

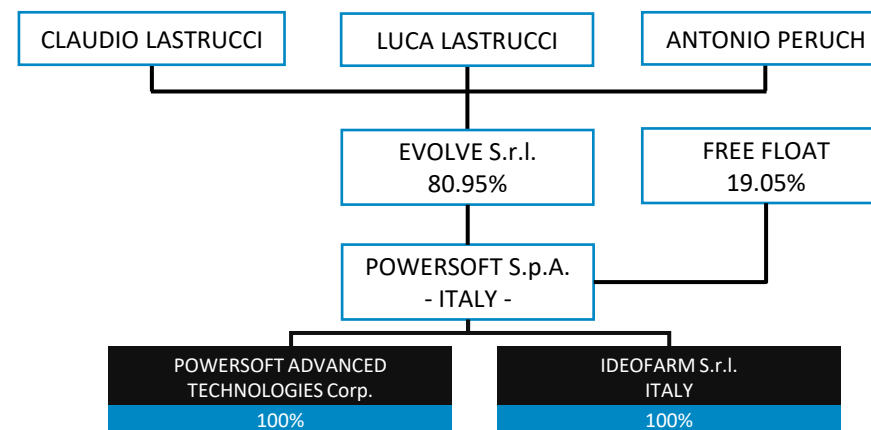

MARKET SETTER OF UNRIVALLED CUTTING-HEDGE PRODUCTS

SAFETY MULTIMEDIA DEVICES



DEVA

CONTROLLER



WM TOUCH

TRANSDUCERS



IPALMOD



M-FORCE



M-DRIVE



MOVER

RACK AMPLIFIERS



Q SERIES/D SERIES*



DUECANALI SERIES



OTTOCANALI SERIES



MEZZO SERIES



QUATTROCANALI SERIES



TTM



DIGAM 3000*



K SERIES



M SERIES



X SERIES



T SERIES

AMPLIFICATION MODULES



DIGIMOD



DIGIMOD PFC



D-CELL 504



DIGIMOD PFC2/PFC4



DIGIMOD IS



LITEMOD



MINIMOD



LOTO

1995-2003

2004-2009

2010-2013

2014-2019

2020-2021 →



MUSIC CLUB SYSTEM

BASE NIGHTCLUB
DUBAI, UAE



CHALLENGE:

Open-air nightclub with the requirement to complete the project in 23 days.

SOLUTION:

9x **X4 DSP + ETH** to save on power consumption and gain amplification output.

RESULT:

Powersoft provided the most cost-efficient power solution per channel, with much simpler configuration requirements than competing products.

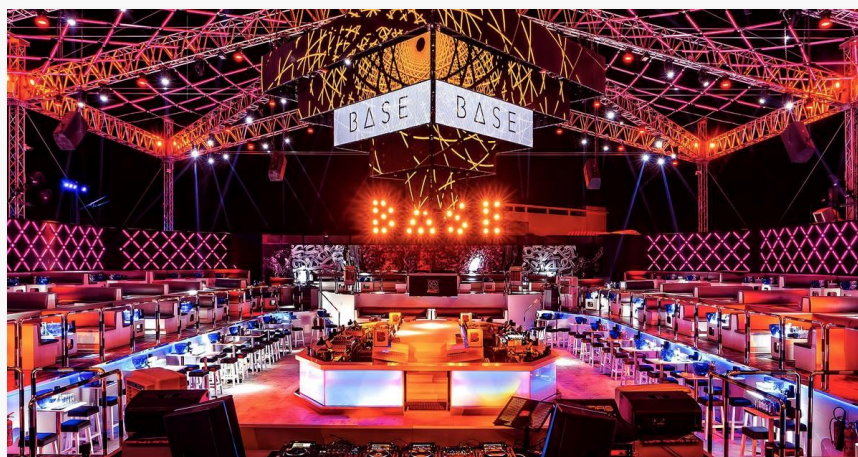

STADIUM SYSTEM

CHALLENGE:

To serve the 59.000-seat stadium with a pristine and broadcast quality sound reinforcement system.

SOLUTION:

4x **Ottocanali 4K4** and 14x **Ottocanali 12K4** taking analogue feeds from Symetrix matrix router's Dante extension cards.

RESULT:

"When people come to this stadium, they get a real show, both visually and sonically. The result is a great installation for football fans which will resonate in the years to come."

- Nicolas Houel,
Technical Manager at OL Images



PARC OLYMPIQUE LYONNAIS STADIUM
LYON, FR

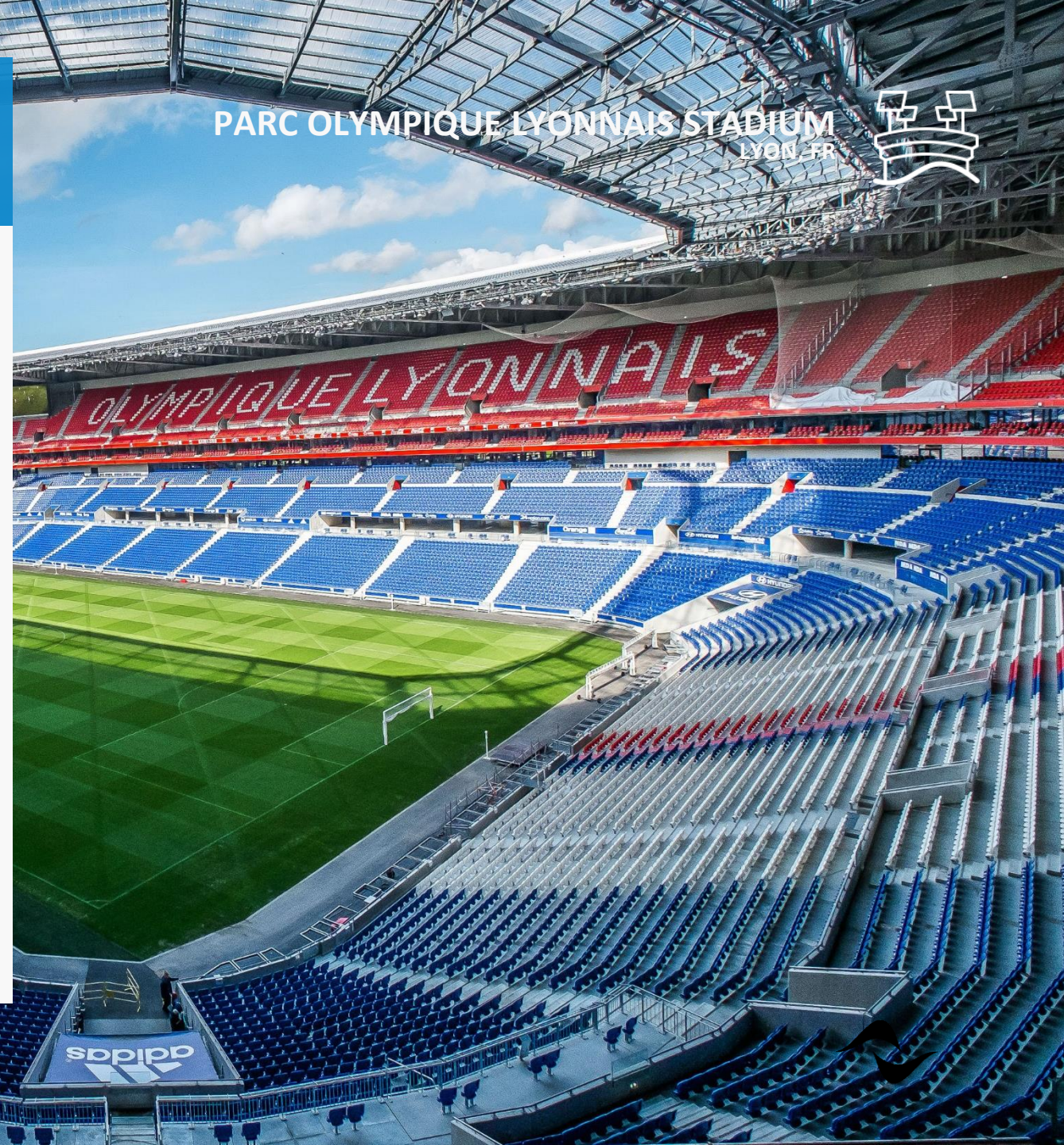

CULTURAL CENTRE

CHALLENGE:

To deliver a high-quality sound system for multi-purpose spaces with a dedicated platform for control and monitoring.

SOLUTION:

Quattrocanali DSP+D and **Duecanali DSP+D**

RESULT:

Customer satisfaction due to amplifier's ease of use and reliability.



HANAHOLMEN
ESPOO, FI



WORK SPACE SYSTEM

CHALLENGE:

A new system for Cross Campus co-working space, to be as networked and automated as possible, in such a way as not to require having a designated sound engineer present for the vast majority of events.

SOLUTION:

2x **Ottocanali DSP+D**, full system tuning with ArmoniaPlus, Dante connectivity and Symetrix integration.

RESULT:

“Powersoft is the only amp manufacturer that would have allowed me to provide the network and DSP functionality this job required while maintaining a healthy, great sounding system.”

- Matt Grossman,
Hollywood Sound Systems



CROSS CAMPUS
LOS ANGELES, USA



SHOPPING CENTRE SYSTEM

CHALLENGE:

A competitive Dante enabled solution for a combination of Hi and Lo-Z speakers distributed in different zones.

SOLUTION:

4x **Ottocanali DSP+D** and 2x **Quattrocanali DSP+D** with full Dante-Symetrix integration.

RESULT:

Flawless system performance and end customer satisfaction.

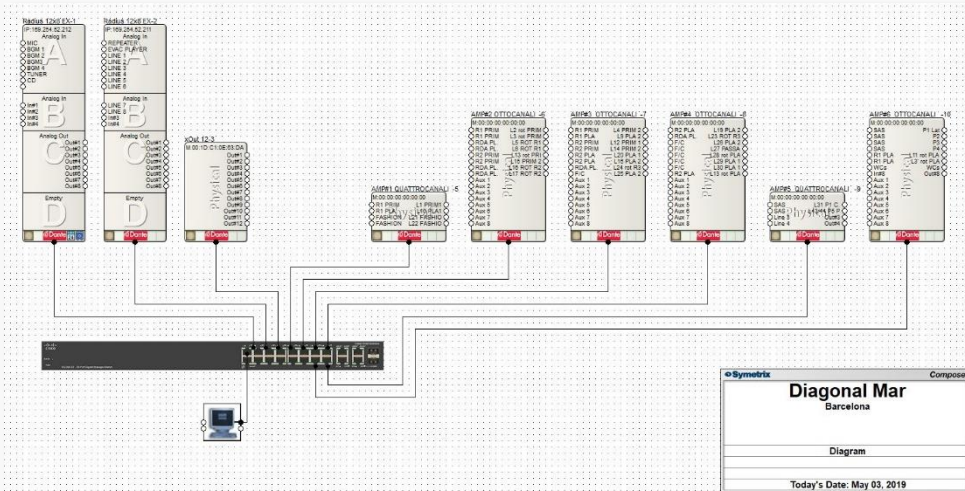

DIAGONAL MAR SHOPPING CENTRE
BARCELONA, ES



RESTAURANT SYSTEM

CHALLENGE:

A reliable and efficient system for background music, night after night. To reduce rack space and installation costs.

SOLUTION:

5x **Quattrocanali** units to replace 12x 2-channel amplifiers mixing Lo-Z and 70-Volt distributed line loads.

RESULT:

Reliable and high-power system with zero service required. Saving on racks, cabling and operational costs.



YARD HOUSE RESTAURANT
DENVER, USA



STADIUM SYSTEM

CHALLENGE:

To provide an amplification solution for the 30,000-seat arena, with low power consumption requirements and low heat dispersion, due to high summer temperatures.

SOLUTION:

4x **Ottocanali 8K4** to replace 12x 3RU pre-existing amplifiers.

RESULT:

"These amplifiers hit a lot harder than others on the market.

The sound and clarity was amazing. One of the first comments came from one of the executives asking if we had installed subwoofers in the system, which of course, we hadn't."

- Nathan Barlow,
Pro AV & Electronics



UNIVERSITY OF NEVADA - MACKAY STADIUM
RENO - NV, USA



HOTEL SYSTEM

CHALLENGE:

A reliable and efficient system to cover background music night after night, while providing sufficient power and headroom for volume boost in DJ nights and special events.

SOLUTION:

1x **Ottocanali 4K4** for the open-air lounge, and 1x **M30D** and 1x **4K4 Ottocanali** and for the penthouse hi-fi sound system.

RESULT:

“The sound quality of Powersoft is second to none, but we also choose Powersoft because of the consistency and reliability”



NAUTILUS HOTEL
MIAMI, USA



DISCLAIMER

“This Presentation contains certain forward-looking statements. Forward-looking statements concern future circumstances and results and other statements that are not historical facts, sometimes identified by the words "believes," "expects," "predicts," "intends," "projects," "plans," "estimates," "aims," "foresees," "anticipates," "targets," and similar expressions. The forward-looking statements contained in this Presentation, including assumptions, opinions and views of Powersoft S.p.A. (“**Powersoft**” or the “**Company**”) or cited from third party sources, are solely opinions and forecasts reflecting current views with respect to future events and plans, estimates, projections and expectations which are uncertain and subject to risks. Market data used in this Presentation not attributed to a specific source are estimates of the Company and have not been independently verified. These statements are based on certain assumptions that, although reasonable at this time, may prove to be erroneous. By their nature, forward-looking statements involve a number of risks, uncertainties and assumptions that could cause actual results or events to differ materially from those expressed or implied by the forward-looking statements. If certain risks and uncertainties materialize, or if certain underlying assumptions prove incorrect, the Company may not be able to achieve its financial targets and strategic objectives. A multitude of factors which are in some cases beyond the Company’s control can cause actual events to differ significantly from any anticipated development. Forward-looking statements contained in this Presentation regarding past trends or activities should not be taken as a representation that such trends or activities will continue in the future. No one undertakes any obligation to update or revise any forward-looking statements, whether as a result of new information, future events or otherwise. Market data used in this Presentation not attributed to a specific source are estimates of the Company and have not been independently verified. Forward-looking statements speak only as of the date of this Presentation and are subject to change without notice. No representations or warranties, express or implied, are given as to the achievement or reasonableness of, and no reliance should be placed on, any forward-looking statements, including (but not limited to) any projections, estimates, forecasts or targets contained herein. Powersoft does not undertake to provide any additional information or to remedy any omissions in or from this Presentation. Powersoft does not intend, and does not assume any obligation, to update industry information or forward-looking statements set forth in this Presentation. This presentation does not constitute a recommendation regarding the securities of the Company.

This Presentation is not an offer, or a solicitation of an offer, to buy, sell or exchange any securities in Italy, pursuant to Section 1, letter (t) and letter (v) of Legislative Decree no. 58 of February 24, 1998, or in any other country or state and is not a prospectus or an offer document within the meaning of Italian laws and regulations.

It should be noted that the audit of the Draft Financial Statements has not yet been finalised and that the Independent Auditors' Report will therefore be made available within the terms required by law. It should be also noted that Income Statement and Balance Sheet shown in this Presentation are reclassified and not subject to audit by the Independent Auditors.”





Powersoft S.p.A.

Via Enrico Conti,5
50018 Scandicci

 www.powersoft.com



Euronext Growth Advisor

Banca Finnat
+39 39 06 69933215

Specialist

Banca Profilo S.p.A.
+39 02 584081

Corporate Broker

Alantra Capital Markets
+39 02 63671601



IR Manager

Massimo Ghedini
ir@powersoft.com
Ph. +39 055 7350230

IR Advisor

Vincenza Colucci – **CDR Communication**
vincenza.colucci@cdr-communication.it
M. +39 335 6909547
Federico Bagatella – **CDR Communication**
federico.bagatella@cdr-communication.it
M. +39 335 8277148



The information contained in these documents is confidential and only for the information of the intended recipient and may not be used, published or redistributed without the prior written consent of Powersoft S.p.A. All forecasts included in this document are subject to risks and uncertainties of Powersoft itself and of markets. All forecasts are based on currently available information and reflect our management expectations. All forecasts reflect market parameters, assumptions and other fundamentals which could change and therefore influence the future results. All the forecasts are based on an hypothesis of organic growth and commercial and regulatory stability.

